

# NOTICE DE MONTAGE-ASSEMBLY INSTRUCTIONS- MONTAGEANLEITUNG- MANUAL DE MONTAJE- MANUAL DE MONTAGEM

creador  
inspired by nature

## SET LIRO

Code: 544086

Ensemble de 4 pièces  
FRS51545+FRS51546+FTS50233

BIEN ETUDIER LA NOTICE DE MONTAGE  
REPEREZ LES PIECES CONSTITUANT VOTRE  
MEUBLE  
REGROUPEZ ET CONTROLEZ LA QUINCAILLERIE  
MUNISSEZ-VOUS DE L'OUTILLAGE NECESSAIRE  
AMENAGEZ-VOUS UNE ZONE DE MONTAGE  
PROCEDEZ AU MONTAGE  
NE JAMAIS FORCER LES ASSEMBLAGES  
RESSERREZ LES VIS APRES QUELQUES TEMPS  
D'USAGE  
GARDER VOTRE NOTICE DE MONTAGE, SI UNE PIECE  
VENAIT A MANQUER, ELLE SERAIT LE  
PLUS CLAIR MOYEN DE COMMUNIQUER AVEC  
VOTRE MAGASIN.

READ THE ASSEMBLY INSTRUCTIONS CAREFULLY  
IDENTIFY THE ELEMENTS CONSTITUING YOUR  
PIECE OF FURNITURE  
GROUP AND CHECK THE HARDWARE FITTINGS  
GET THE TOOLS NEEDED  
CLEAR SPACE TO WORK  
PROCEED TO ASSEMBLE  
NEVER FORCE THE FITTINGS  
TIGHTEN THE SCREW AFTER USING FOR  
SOMETIME  
KEEP YOUR ASSEMBLY INSTRUCTIONS, IT  
COULD HELP FOR BETTER COMMUNICATION  
WITH YOUR STORE, IN THE EVENT OF QUERY.

DIE MONTAGEANLEITUNG SORGFÄLTIG DURCHLESEN  
DIE EINZELTEILE DES MÖBELSTÜCKS ERMITTELN  
DIE BESCHLÄGE ZUSAMMENLEGEN UND PRÜFEN  
DAS NOTWENDIGE WERKZEUG ZURECHTLEGEN  
EINEN MONTAGEBEREICH FREIMACHEN  
DAS MÖBELSTÜCK ZUSAMMENBAUEN  
NIEMALS DIE VERBINDUNGEN ZU STARK ANZIEHEN  
DIE SCHRAUBEN NACH EINIGER ZEIT DES  
GEBRAUCHS ERNEUT FESTZIEHEN  
DIE MONTAGEANLEITUNG GUT AUFBEWAHREN:  
SOLLTE EIN TEIL FEHLEN, IST SIE DAS BESTE  
VERSTÄNDIGUNGSMITTEL MIT IHREM GESCHÄFT

ESTUDIE ATENTAMENTE EL MANUAL DE  
MONTAJE  
LOCALICE LAS PIEZAS QUE CONSTITUYEN SU  
MUEBLE  
REUNA Y CONTROLE LOS TORNILLOS  
EQUIPE-SE DE LAS HERRAMIENTAS  
NECESARIAS  
PREPARE UMA ZONA DE MONTAJE  
REALICE EL MONTAJE  
NO FUERCE NUNCA EN LAS UNIONES  
APRIETE LOS TORNILLOS DESPUES DE CIERTO  
TIEMPO DE UTILIZACION  
CONSERVE SU MANUAL DE MONTAJE, SI  
FALTARA UNA PIEZA, SERIA LA MANERA MAS  
FACIL DE COMUNICAR CON LA TIENDA



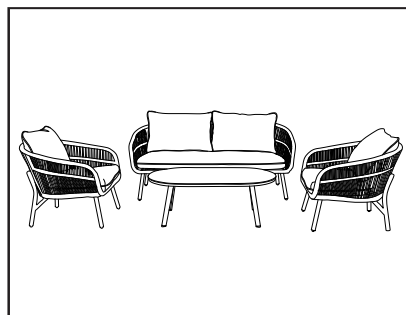
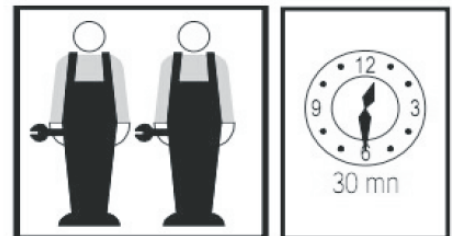
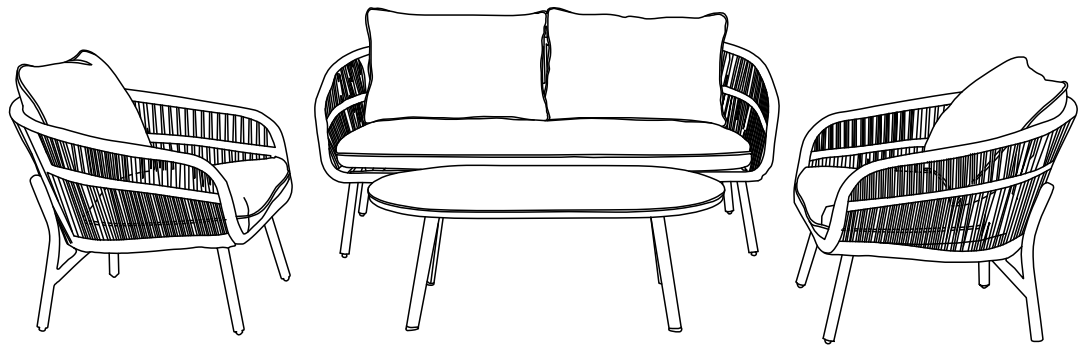









LEIA ATENTAMENTE O MANUAL DE INSTALAÇÃO  
IDENTIFICAR OS ELEMENTOS ESTÃO SEUS MÓVEIS  
AGRUPE E VERIFIQUE OS PARAFUSOS  
EQUIPE-SE DAS FERRAMENTAS NECESSÁRIAS  
PREPARAR UMA ÁREA DE MONTAGEM  
REALICE O MONTAGEM  
NUNCA FORCE NAS UNIÕES  
APERTAR DEPOS DE ALGUM TEMPO DO USO  
GUARDE AS INSTRUÇÕES. SE FALTA UMA PEÇA A  
MANEIRA MAIS FÁCIL ES COMUNICAR A LOJA



Acier/ Polyester

Plateau Fairstone®: silice et alumine

# LISTE DES PIECES

A		1
B		4
C		2
D		1
E		6
F		6
G		4
H		2
I		1
J		48
K	 M6 x 20	48
L	 ø13 x ø6.5 x 1	48
M		1

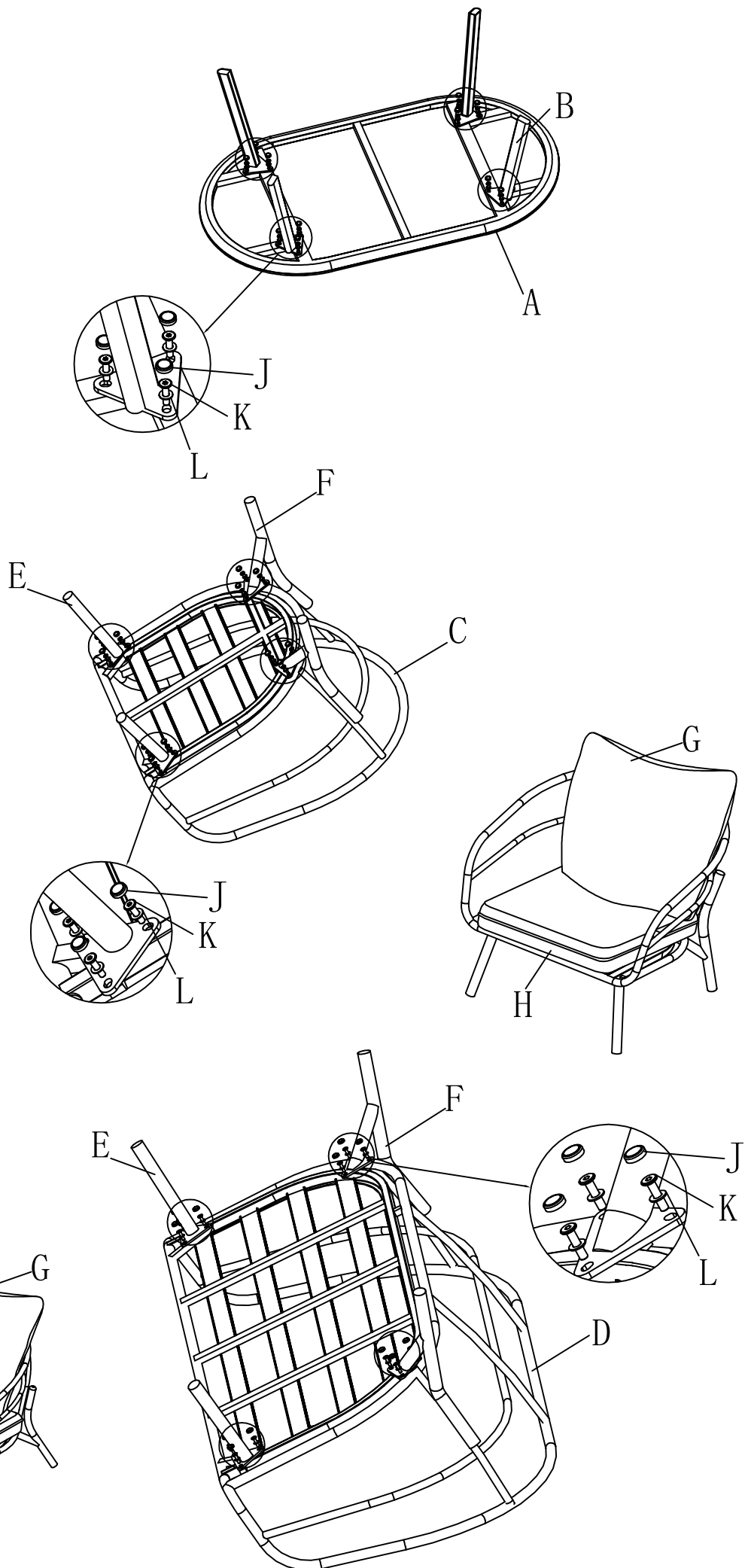



1.2



M×1



J×12

全部螺丝锁紧, 再盖螺母盖

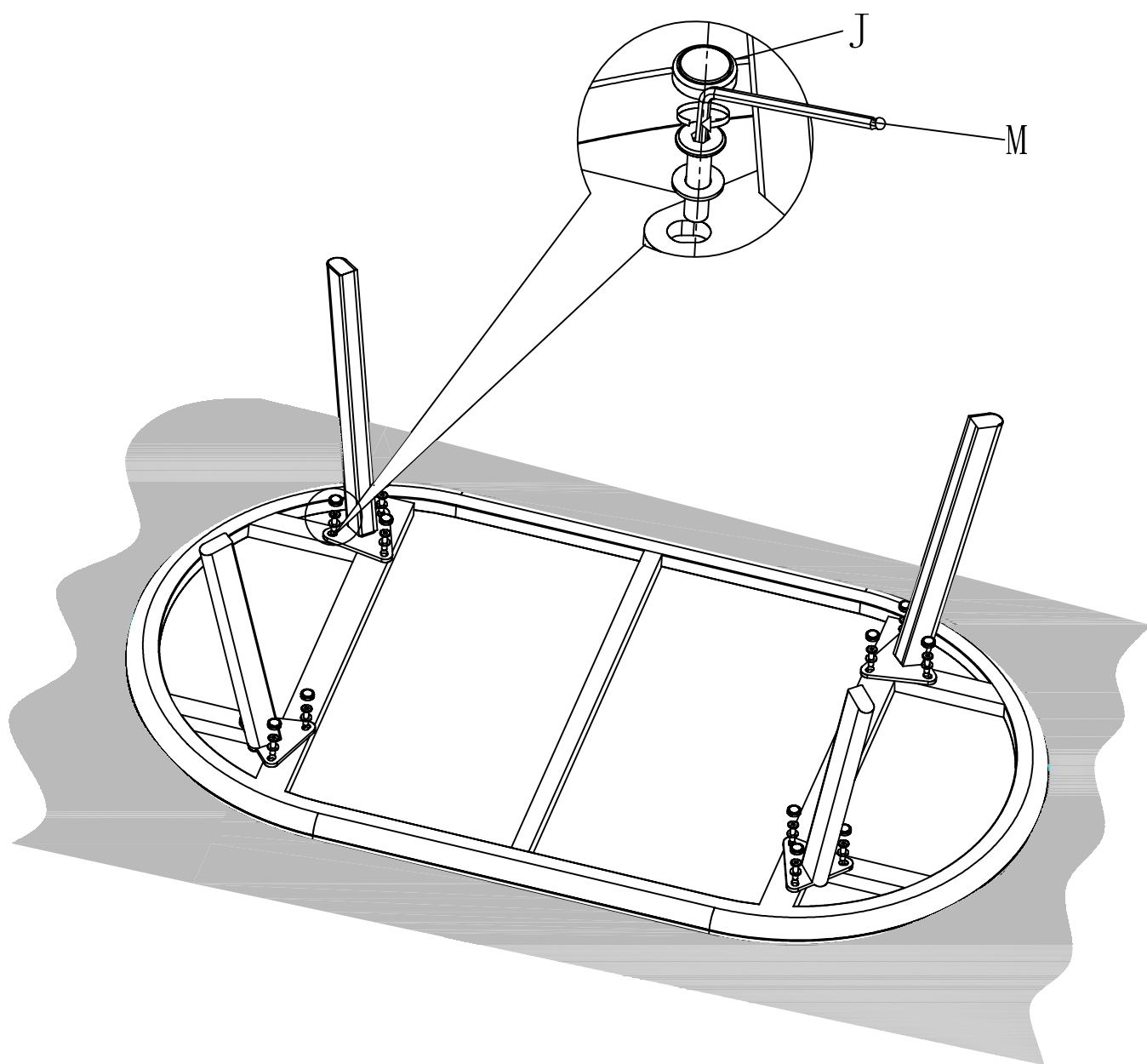

1.1

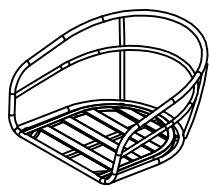

C×1

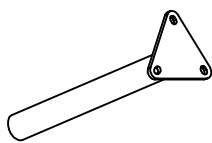

E×2

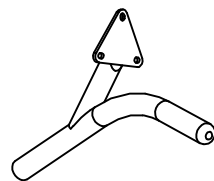

F×2

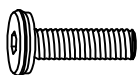

K×12  
(M6×20)



L×12  
(∅13×∅6.5×1)

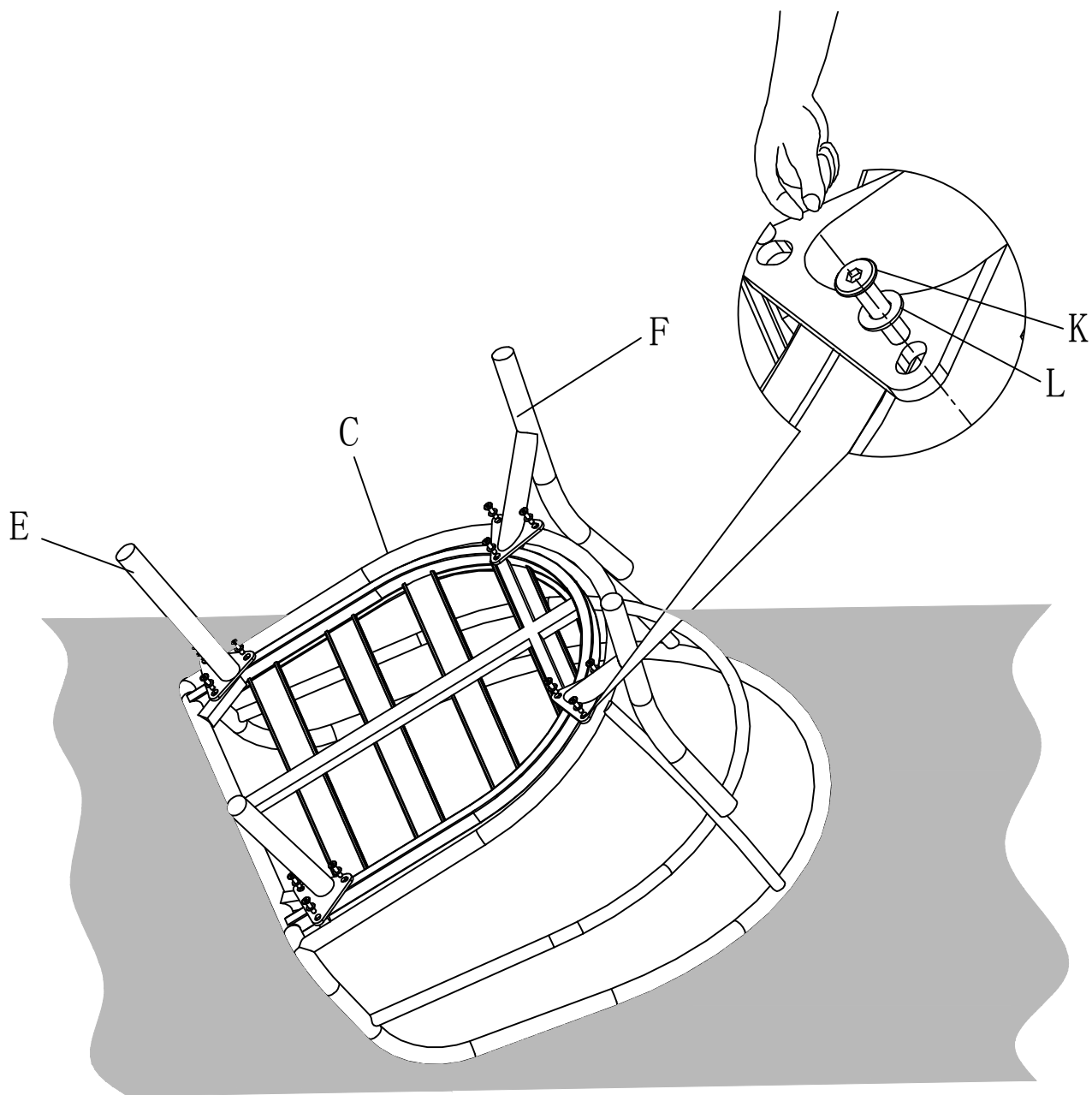

1.2



M×1



J×12

全部螺丝锁紧, 再盖螺母盖

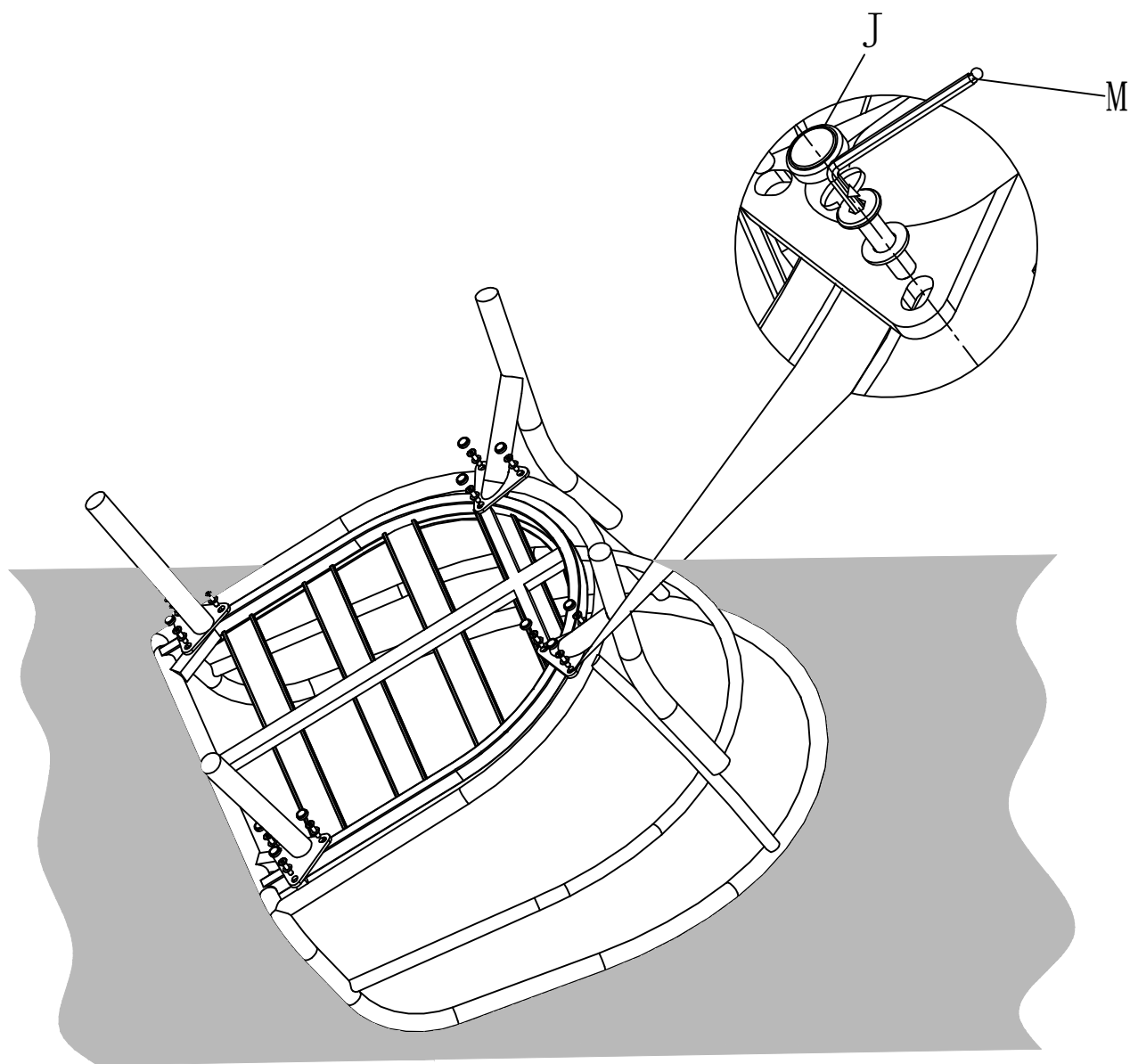

1.3

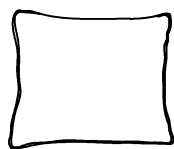

G×1

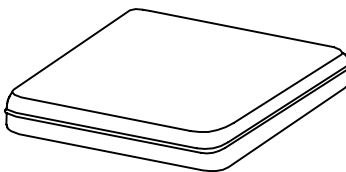

H×1

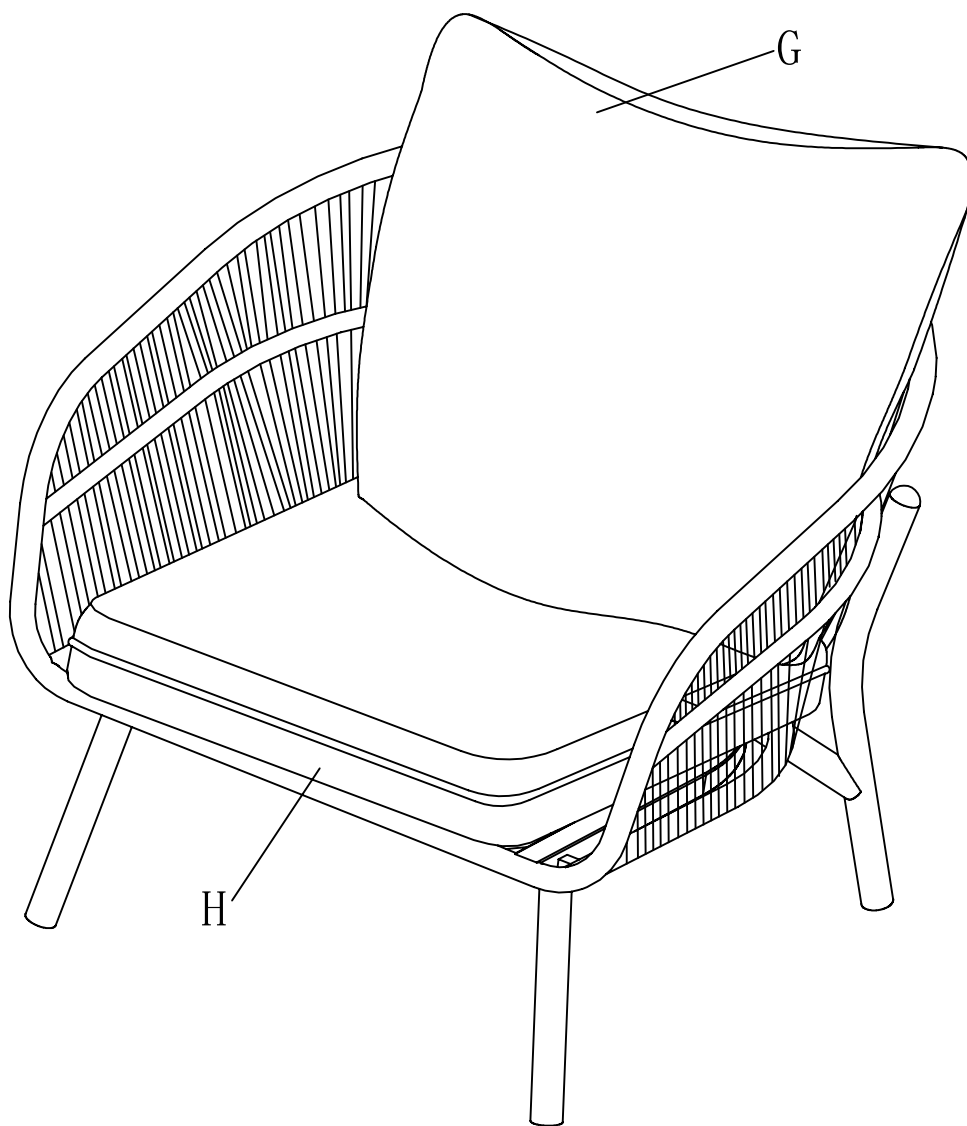

1.1

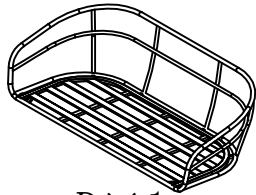

D x 1

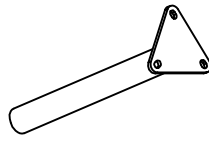

E x 2

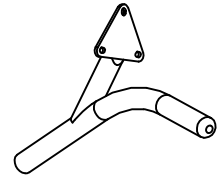

F x 2

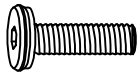

K x 12  
(M6 x 20)



L x 12  
(ø13 x ø6.5 x 1)

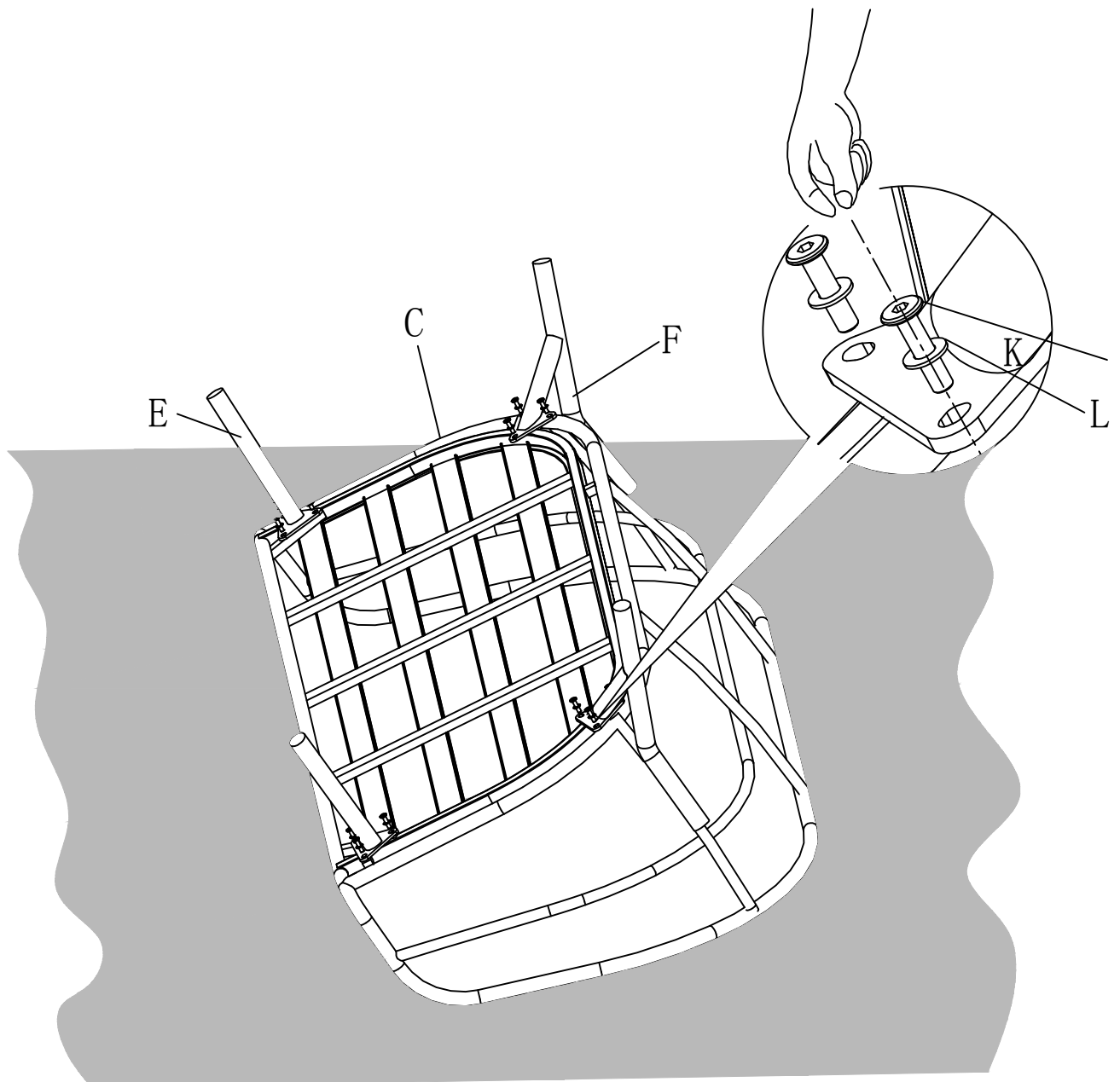



1.2



M×1



J×12

全部螺丝锁紧, 再盖螺母盖

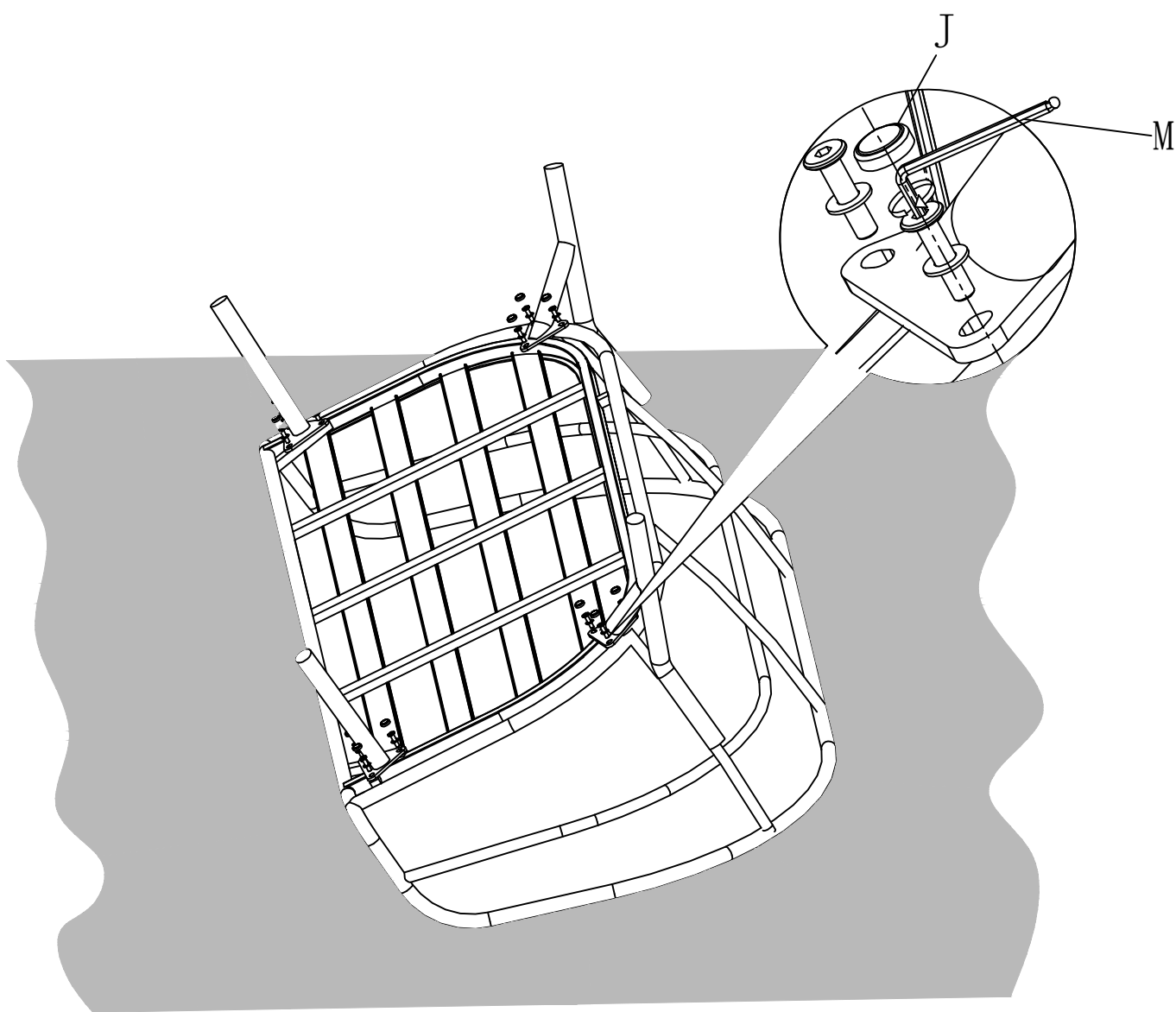

1.3

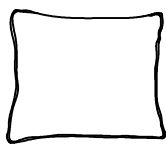

G×2

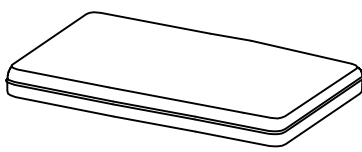

I×1

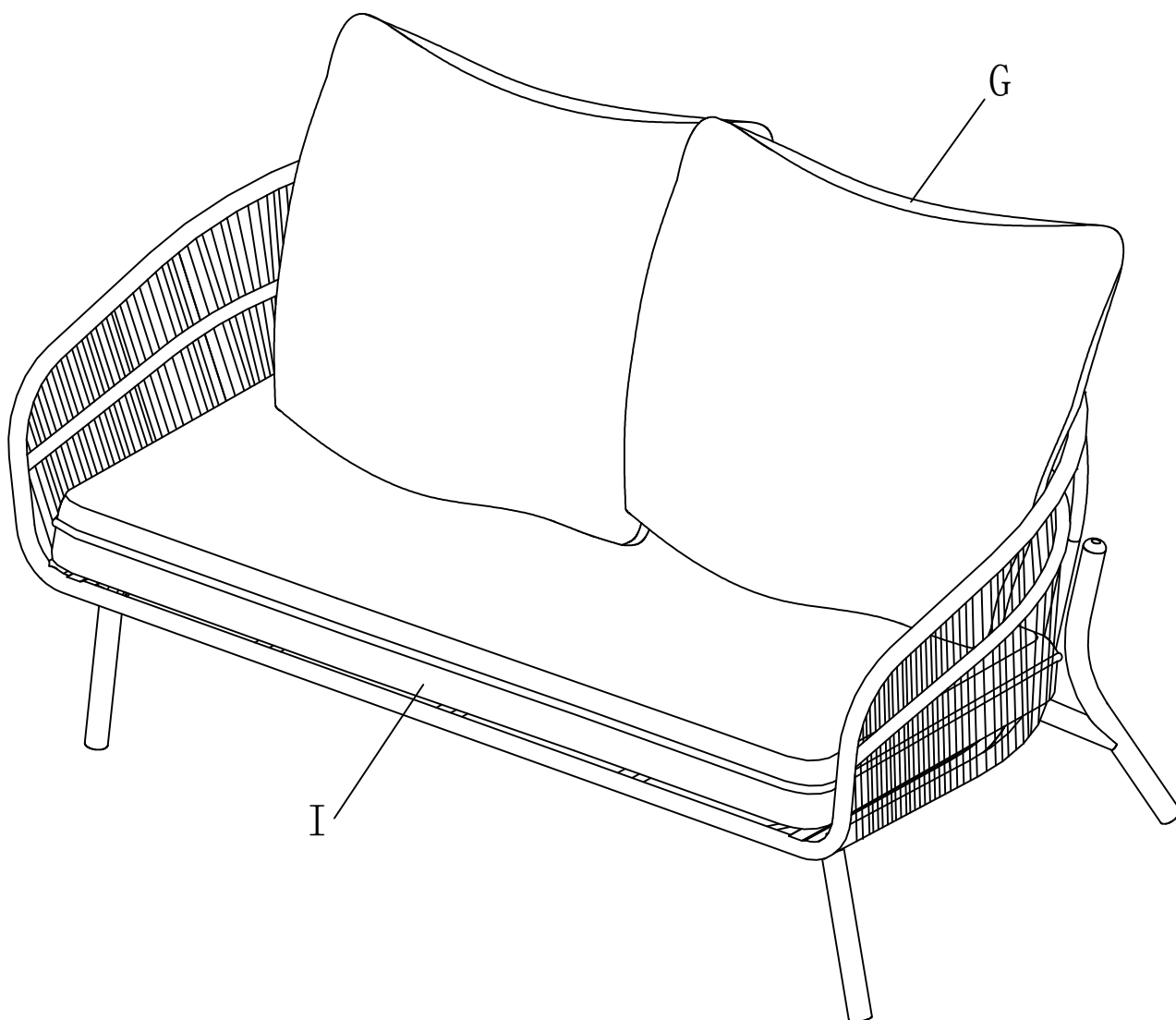

## REMERCIEMENTS

**Vous avez choisi d'acheter ce produit chez CREADOR. Nous espérons que vous en serez entièrement satisfait et vous remercions de votre confiance.**

**Si toutefois vous aviez remarqué un problème en cours de montage, appelez vite votre magasin qui vous apportera la solution adéquate.**

**Vous pouvez également nous écrire à l'adresse suivante :**

## WITH THANKS

**You have decided to buy a product from CREADOR. We thank you for your trust and hope you are fully satisfied with your purchase.**

**If for any reason you encounter a problem when assembling this item, quickly call your shop which will provide you with a suitable solution.**

**You can also contact us at the following address :**

## DANKE

**Sie haben beschlossen, dieses Produkt bei CREADOR zu kaufen. Wir hoffen, daß es Sie vollauf zufriedenstellt und danken Ihnen für Ihr Vertrauen.**

**Sollten Sie jedoch während der Montage auf ein Problem gestoßen sein, rufen Sie bitte schnell unser Geschäft an, das Ihnen die passende Lösung bringt.**

**Sie können uns auch unter folgender Adresse schreiben:**

## AGRADECIMIENTOS

**Usted ha escogido comprar este producto en CREADOR. Esperamos que esté completamente satisfecho de eso y le agradecemos su confianza.**

**No obstante, si usted hubiese observado algún problema durante el montaje, lláme rápido a su tienda, ésta le dará la solución adecuada.**

**También puede escribirnos a la siguiente dirección :**

## AGRADECIMIENTOS

**Você optou por comprar este produto CREADOR. Esperamos que você esteja completamente satisfeito com isso e agradecemos a sua confiança.**

**No entanto, se você tivesse visto algum problema durante a instalação, chame rápido a sua loja, ele vai te dar a solução certa.**

**Você também pode escrever para o seguinte endereço:**

<p>"Utilisation domestique uniquement"</p>	<p>A nettoyer à l'eau 30°C maximum et au savon à la main Laisser sécher à l'ombre et à stocker dans un endroit sec et ventilé à l'abri A positionner sur un sol plat</p>	<p>"A monter soi même"</p>
<p>For domestic use only</p>	<p>Clean by hand with water and mild soap with a maximum temperature of 30°C Leave to dry in the shade and store in a dry and ventilated place during winter Position in a stable way on a flat ground</p>	<p>Easy self-assembly</p>
<p>Nur für den Hausgebrauch bestimmt.</p>	<p>Bitte mit einer milden Seifenlauge und einer Höchsttemperatur von 30°C reinigen. Bitte im Schatten trocknen lassen und den Winter über in einem trockenen Platz aufbewahren. Vor Gebrauch auf einem festen Grund aufstellen</p>	<p>Einfache Selbstmontage</p>
<p>Alleen voor thuisgebruik.</p>	<p>Graag met een zachte zeep en water met een maximaal temperatuur van 30°C schoonmaken en in de schaduw laten drogen. Tijdens de winter maanden in een droge plaats opbergen. Voor gebruik op een vlakke grond positioneren</p>	<p>Eenvoudig zelf te monteren</p>
<p>Para uso doméstico.</p>	<p>Limpiar a mano con agua y un jabón suave a una temperatura de unos 30°C, Dejar secar en la sombra y guardar en un lugar seco y ventilado durante el invierno. Colocar de una manera estable en una superficie plana</p>	<p>Montaje sencillo</p>
<p>Para uso doméstico</p>	<p>Limpe a mão com sabão neutro e água a uma temperatura de cerca de 30°C. Deixe secar à sombra e armazenar em local seco e ventilado durante o inverno. Coloque em uma forma estável em um superfície plana</p>	<p>Montaje sencillo</p>

Importé par  
MWH GMBH  
Blindeisenweg 23  
41468 Neuss  
Allemagne  
SAV France : sav.creador@mwhgmbh.de  
**SAV Germany: info@mwhgmbh.de**  
Merci de joindre une photo et la facture d'achat



## **A CONSERVER POUR LECTURE ULTERIEURE**

GARANTIE FABRICANT 2 ANS date d'achat

Envoi de pièces détachées sur justificatif d'achat (ticket de caisse ou facture)

En cas de demande d'échange ou de casse liée au transport, veuillez contacter le revendeur

### **Champs d'application :**

- Utilisation dans les conditions normales et conformes aux conseils d'utilisation, d'entretien et dans le cadre d'un usage privatif des caractéristiques mécaniques, à l'exclusion des caractéristiques cosmétiques.
- Limite géographique : France continentale
- Exclusions : Plateaux de verre et toiles

Sav.creador@mwhgmbh.de

SAV Germany:info@mwhgmbh.de